

# Causeway Link The Smiling Bus

NOTICE TO CUSTOMERS

## CW6 – Change of First Pick-up point to Giant, Nusa Bestari

Date: 14<sup>th</sup> Aug 2012

Attention: All Passengers of Route CW6

**Effective Date:**  
25<sup>th</sup> Aug 2012

Due to unforeseen circumstances, the existing first CW6 pick-up point at Jln Indah 22/3, Bukit Indah 2 will be relocated to Giant, Nusa Bestari. Therefore the bus routing will be revised accordingly. Passengers are to note the followings:-

1. Bus timing from Giant are available as follows only :-

Weekdays (Mon-Fri)  
15-25 mins interval

Saturday  
15-20 mins interval

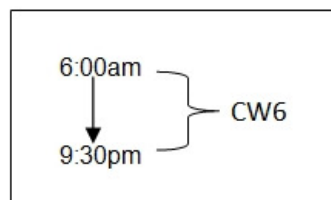
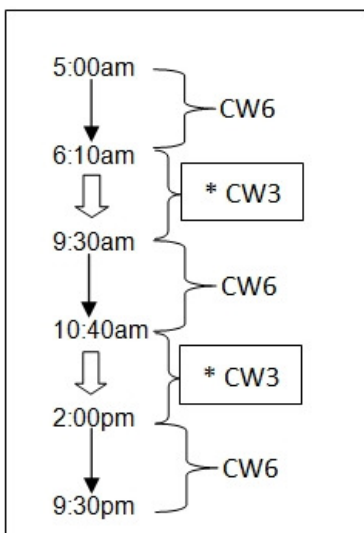

Sunday & S'pore PH  
15-20 mins interval

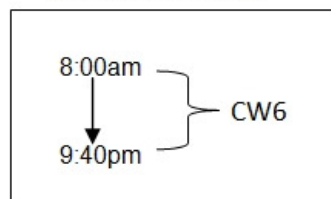

**Note :**

\* An alternate bus service is available by taking CW3 from across the road & transit to CW6 at Tuas checkpoint to get to Boon Lay

\* Please take CW3 if CW6 bus service is unavailable

2. CW6 bus service starts and terminates at Giant, Nusa Bestari. Passengers going/coming back to Perling need to take CW3 from CIQ 2<sup>nd</sup> Link.

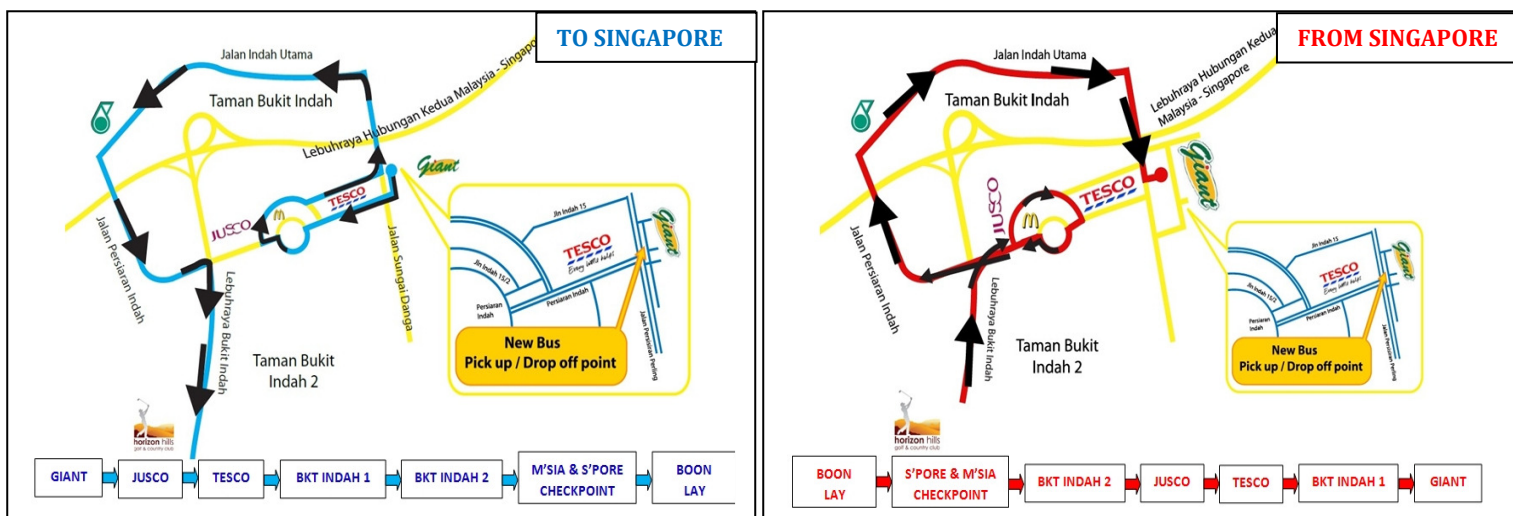

Any enquiries or feedback, kindly contact +607 360 2244 or email to [feedback@support.causewaylink.com.my](mailto:feedback@support.causewaylink.com.my)

Official website: [www.causewaylink.com.my](http://www.causewaylink.com.my)



[www.facebook.com/causewaylink](http://www.facebook.com/causewaylink)